



**MANUAL DE MONTAGEM
ASSEMBLY INSTRUCTIONS
INSTRUCCIONES DE MONTAJE**

Sumário Summary Resumen

Introdução Introduction Introducción	-----	3
Antes de começar Before starting Antes de comenzar	-----	4
Evite acidentes Avoid accidents Evitar accidentes	-----	4
Dimensões e ferramentas Dimensions and tools Dimensiones y herramientas	-----	5
Identificação das peças Identifying parts Identificación de las piezas	-----	6
Acessórios incluídos na caixa Hardware included in box Accesorios incluidos en la caja	-----	7
Montagem do móvel Furniture assembly Montaje del mueble	-----	8

Introdução Introduction Introducción

Leia atentamente este manual e siga os passos indicados para que o produto não perca a garantia e também para uma perfeita montagem.

Read this manual and follow the steps in order to keep the guarantee and also for the perfect fit.

Lea este manual y siga los pasos para que el producto no pierda la garantía y también para el ajuste perfecto.

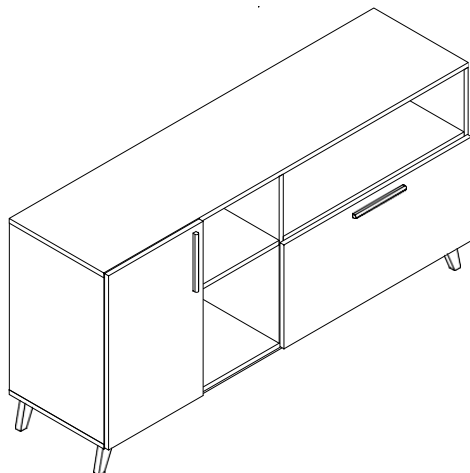

Antes de começar Before starting Antes de comenzar

Antes de começar a montagem prepare o ambiente, deixando-o completamente limpo e com bom espaço para iniciar o trabalho.

Prepare the room before starting the assembly, leaving it completely clean and the area in good condition to start the work.

Antes de comenzar el montaje preparar el ambiente, dejándolo completamente limpio y con bueno espacio para comenzar el trabajo.

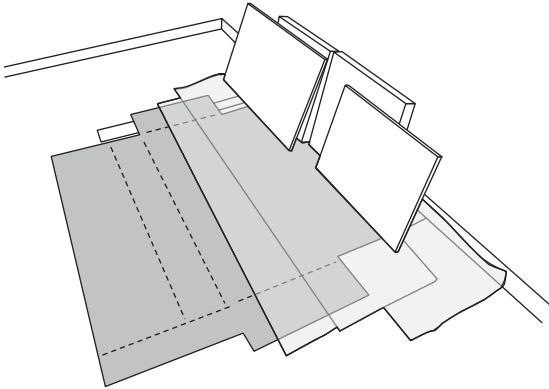

Utilize o papelão da própria embalagem para separar e apoiar as peças retiradas das caixas.

Use the cardboard of the packaging to separate and support the parts removed from the boxes.

Utilice el cartón de la embalaje para separar y apoyar las piezas desmontadas de las cajas.

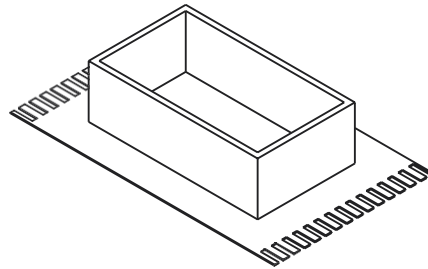

Forre a área de montagem com um cobertor ou tapete. Assim, você evita avarias nas peças durante o processo de montagem.

Cover the assembly area with a blanket or carpet to avoid damaging the parts during the assembly process.

Cubrir la zona de ensamble con una manta o alfombra. De este modo, se evitan daños en las piezas durante el proceso de montaje.



Evite acidentes Avoid accidents Prevenir accidentes

Solicitamos observar atentamente as orientações de montagem como: fixação do produto na parede, colocação de cola em locais específicos necessários, o peso suportado pelo produto, etc...

We request you to carefully observe the assembly instructions as: fixing the product on the wall, adding glue in needed and specific places, product weight limit, etc.

Pedimos que lea atentamente las instrucciones, principalmente las informaciones de fijación del producto en la pared, colocación de pegamento en local específico y necesario, el peso soportado por el producto etc...

Não escale ou se apoie no móvel.

Do not climb or lean on the furniture.

No se suba ni se apoye en el mueble.

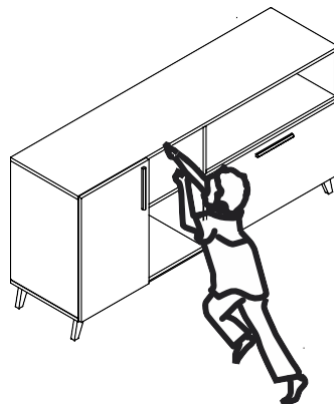

Dimensões e ferramentas
Dimensions and tools
Dimensiones y herramientas

Dimensões:

L: 1350 A: 665 P: 365 mm

Dimensions:

W: 53.14 H: 26.18 D: 14.37 inches

Dimensiones:

L: 1350 A: 665 P: 365 mm

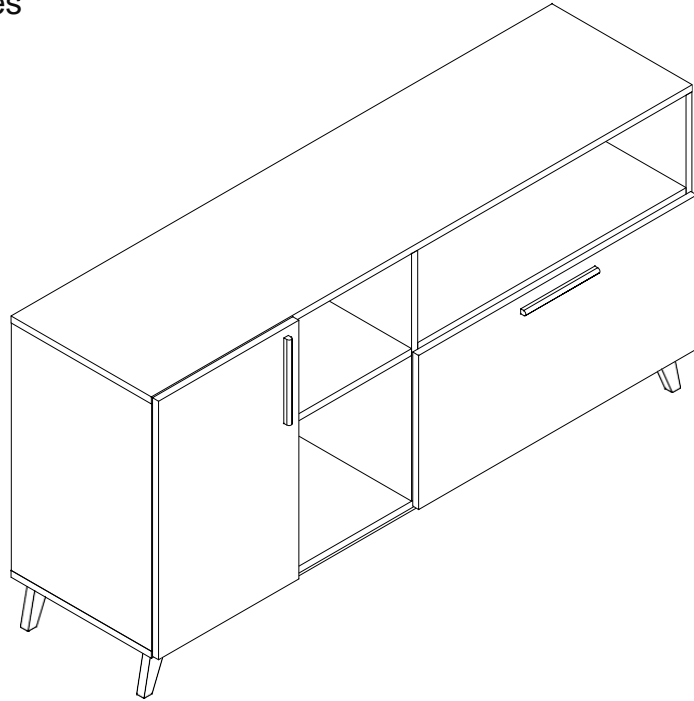

Limpeza
Cleanig
Limpieza

Pano levemente umedecido com água, seguido de pano seco, não utilizar produtos químico ou abrasivos.
Slightly dampened cloth and after a dry cloth, do not use chemicals or abrasives.
Solamente utilizar un paño húmedo y después un paño seco, no utilice productos químicos o abrasivos.

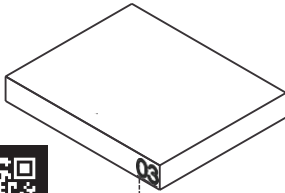

UTILIZE ALCOOL APENAS PARA REMOVER O NUMERO DAS PEÇAS
USE ALCOHOL ONLY TO REMOVE PART NUMBERS
UTILICE ALCOHOL SOLAMENTE PARA ELIMINAR EL NUMERO DE LAS PIEZAS

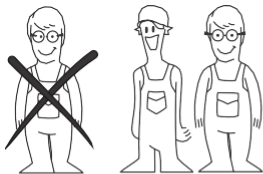

Para facilitar a montagem, utilize uma parafusadeira elétrica.
To improve assembly, use an electronic screwdriver.
Para facilitar el armado, utilice un destornillador eléctrico.

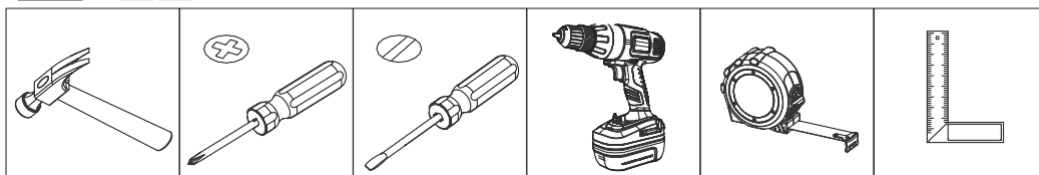

PEÇA	DESCRIÇÃO	QUANT.	PART	DESCRIPTION	QTY	PIEZA	DESCRIPCIÓN	CANTIDAD
001	BASE	1	001	BASE	1	001	BASE	1
002	TAMPO	1	002	TOP	1	002	TAPA	1
003	LATERAL ESQUERDA	1	003	LEFT SIDE	1	003	LATERAL IZQUIERDA	1
004	LATERAL DIREITA	1	004	RIGHT SIDE	1	004	LATERAL DERECHA	1
005	DIVISÓRIA ESQUERDA	1	005	LEFT PARTITION	1	005	PARTICIÓN IZQUIERDA	1
006	DIVISÓRIA DIREITA	1	006	RIGHT PARTITION	1	006	PARTICIÓN DERECHA	1
007	PRATELEIRA ESQUERDA	1	007	LEFT SHELF	1	007	REPISA IZQUIERDA	1
008	PRATELEIRA CENTRAL	1	008	CENTRAL SHELF	1	008	REPISA CENTRAL	1
009	PRATELEIRA DIREITA	1	009	RIGHT SHELF	1	009	REPISA DERECHA	1
010	PORTA MENOR	1	010	LOWER DOOR	1	010	PUERTA MENOR	1
011	PORTA MAIOR	1	011	LONGER DOOR	1	011	PUERTA MAYOR	1
012	COSTA A	1	012	BACK A	1	012	REVÉS A	1
013	COSTA B	1	013	BACK B	1	013	REVÉS B	1
014	COSTA C	1	014	BACK C	1	014	REVÉS C	1
015	PÉS	2	015	FEET	2	015	PIES	2

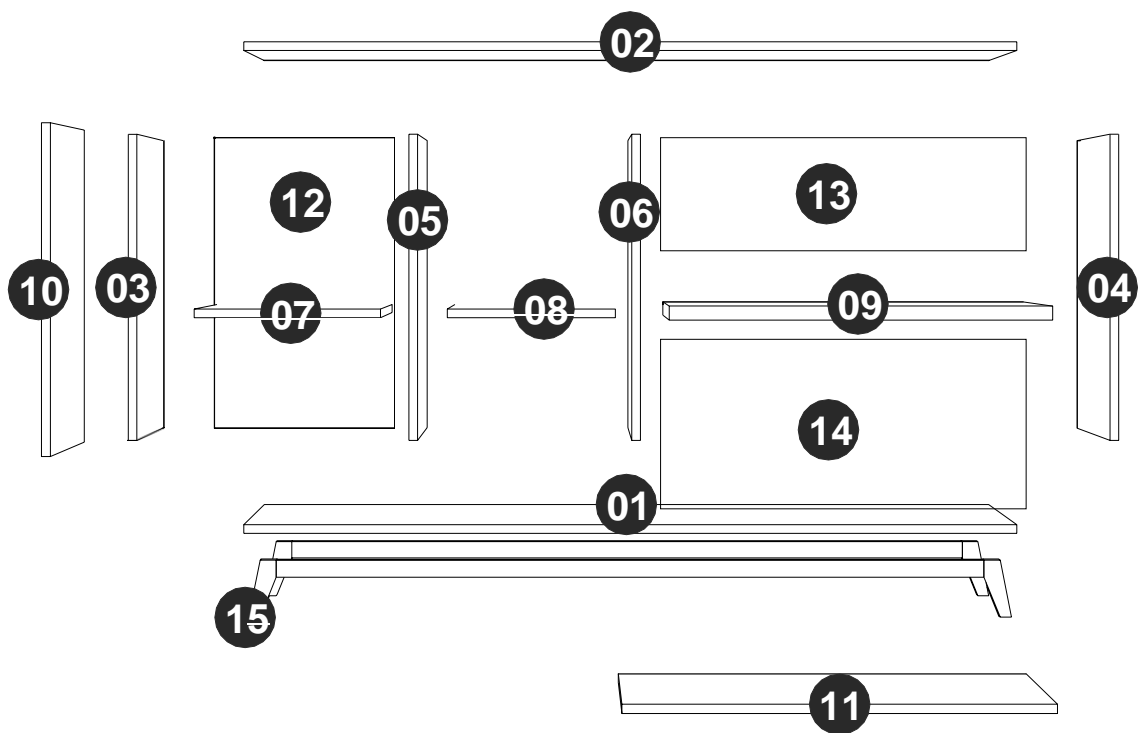

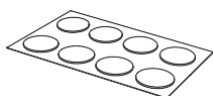

TAPA FUROS x 20
STICKER x 20
TAPAS PLÁSTICAS x 20

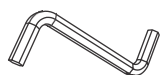

EF 000741 x 1



EF 000106 x 24



EF 000033 x 20



EF 000745 x 4



EF 000132 x 8



EF 000112 x 4



GIZ x 01
CHALK x 01
TIZA x 01



PUXADOR x 2
HANDLE x 2
MANIJA x 2



EF 000216 X 20



EF 000094 X 12



EF 000024 X 2

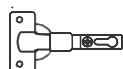

EF 000044 X 2



EF 000067 X 4



EF 000731 x 4

A = 17KG - 37.47LB

B = 8KG - 17.63LB

C = 3KG - 6.61LB

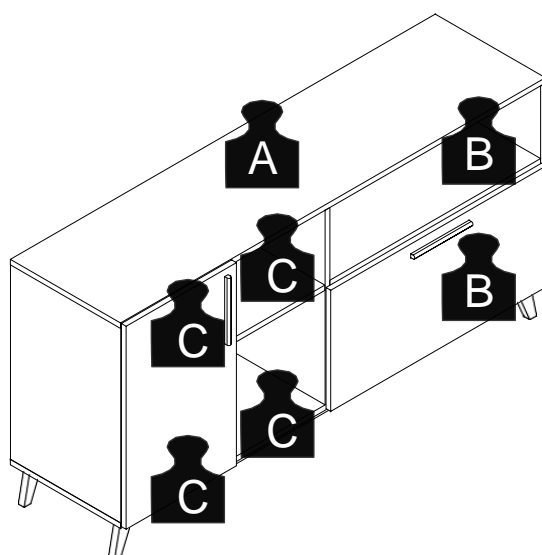

PASSO 1 / STEP 1 / PASO 1

Fixe a ferragem EF 000094 nas peças 02, 03 e 04.
Fix hardware EF 000094 in pieces 02, 03 and 04.
Fije el herraje EF 000094 en las piezas 02, 03 y 04.

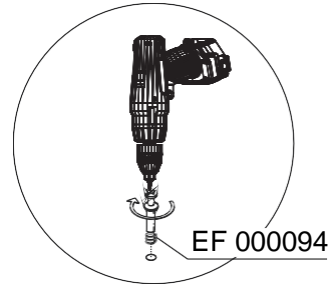
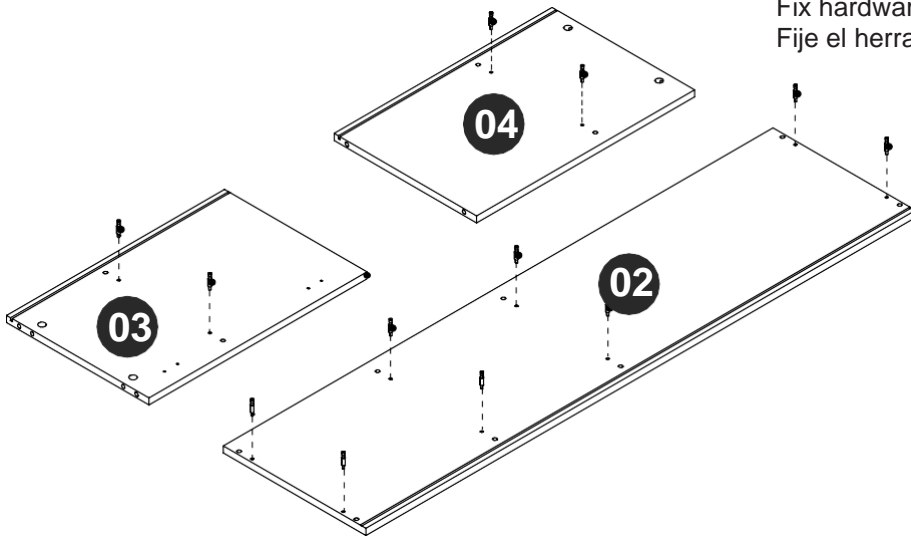

PASSO 2 / STEP 2 / PASO 2

Fixe a ferragem EF 000024 nas peças 01 e 03 utilizando a ferragem EF 000106.
Attach hardware EF 000024 at pieces 01 and 03 using hardware EF 000106.
Fije el herraje EF 000024 en las piezas 01 y 03 utilizando el herraje EF 000106.

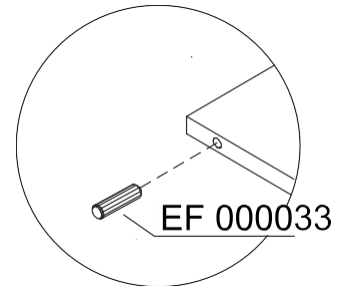
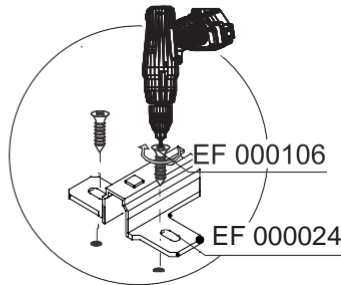
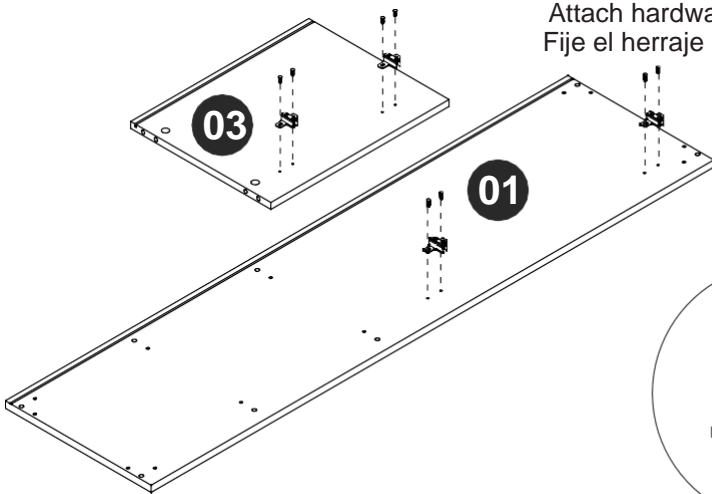

PASSO 3 / STEP 3 / PASO 3

Insira a ferragem EF 000033 nas peças 03, 04, 05, 06, 07 e 09.
Insert hardware EF 000033 into pieces 03, 04, 05, 06, 07 and 09.
Añade el herraje EF 000033 an las piezas 03, 04, 05, 06, 07 y 09.

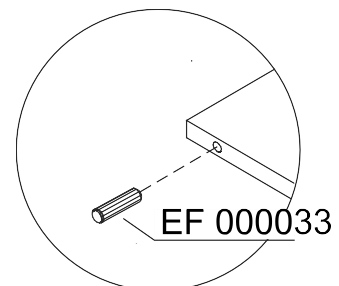
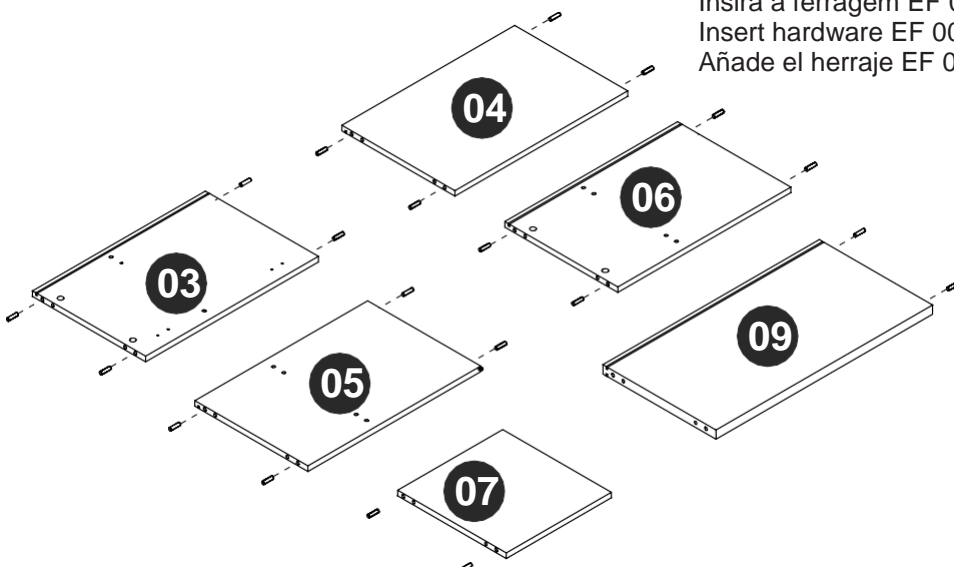

PASSO 4 / STEP 4 / PASO 4

Fixe a ferragem EF 000044 nas peças 10 e 11 utilizando a ferragem EF 000106.
Fixe o puxador usando a ferragem EF 000112.
Attach hardware EF 000044 on pieces 10 and 11 using hardware EF 000106.
Attach the handle using hardware EF 000112.
Fije el herraje EF 000044 en las piezas 10 y 11 utilizando el herraje EF 000106.
Fije la manija utilizando el herraje EF 000112.

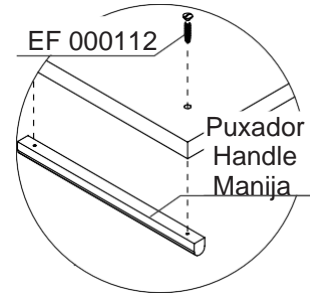
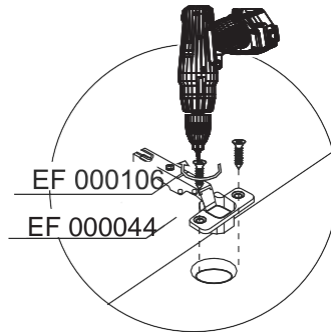
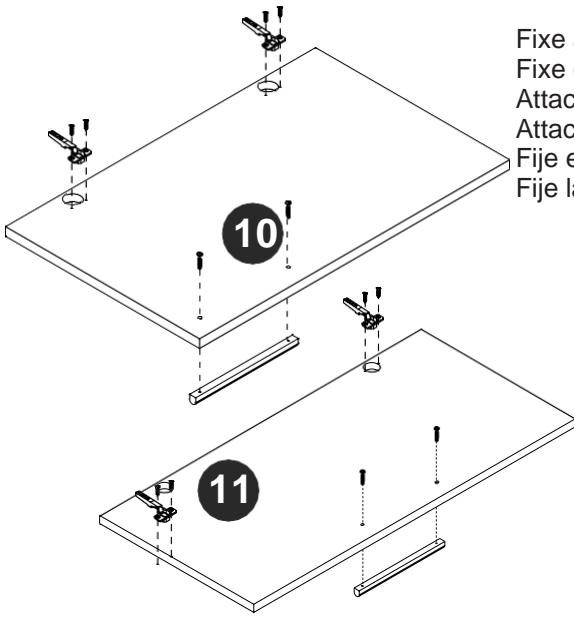

PASSO 5 / STEP 5 / PASO 5

Insira as ferragens EF 000067 e EF 000731 para conectar as peças 05, 07 e 08.
Insira a ferragem EF 000216 e gire para apertar.
Insert hardware EF 000067 and EF 000731 to connect pieces 05, 07 and 08.
Insert hardware EF 000033 and turn to tighten.
Añade los herrajes EF 000067 y EF 000731 para juntar las piezas 05, 07 y 08.
Añade el herraje EF 000033 y gire para apretar.

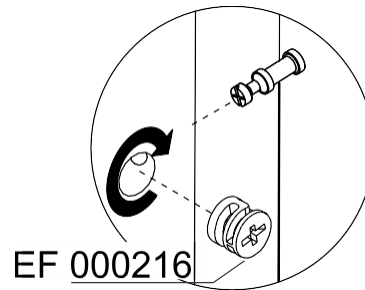
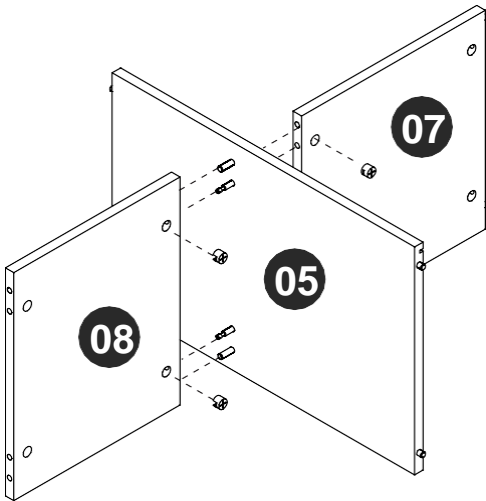

PASSO 6 / STEP 6 / PASO 6

Insira as ferragens EF 000067 e EF 000731 para conectar a peça 09 à parte montada no passo anterior. Insira a ferragem EF 000216 e gire para apertar.
Insert hardware EF 000067 and EF 000731 to connect piece 09 to the part assembled in the previous step. Insert hardware EF 000216 and turn to tighten.
Añade los herrajes EF 000067 y EF 000731 para juntar la pieza 09 a la parte armada en el paso anterior. Añade el herraje EF 000216 y gire para apretar.

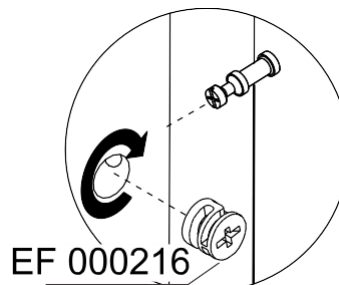
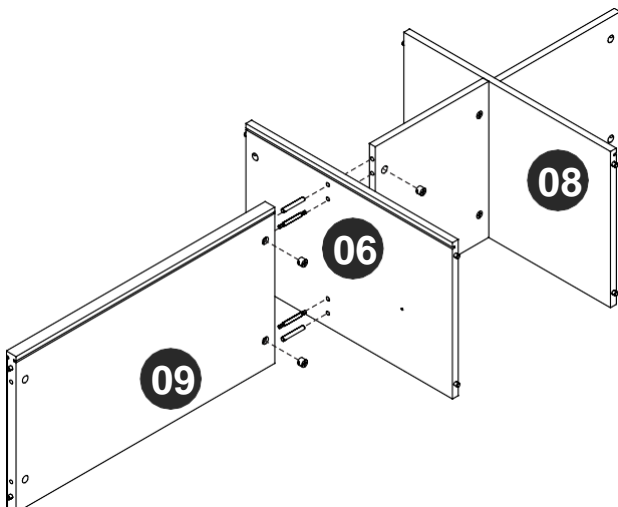

PASSO 7 / STEP 7 / PASO 7

Conecte as peças 03 e 04, insira a ferragem EF 000216 e gire para apertar.
Connect pieces 03 and 04, insert hardware EF 000216 and turn to tighten.
Junte las piezas 03 y 04, añade el herraje EF 000216 y gire para apretar.

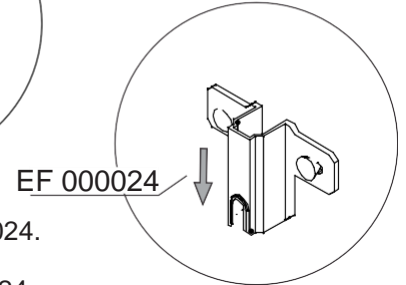
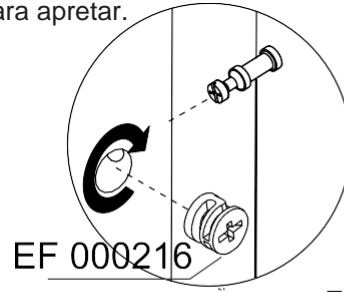
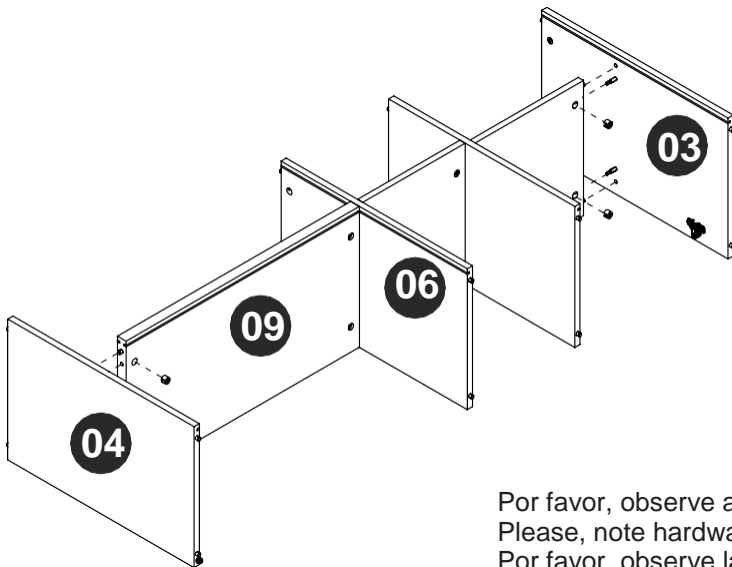

Por favor, observe a posição da ferragem EF 000024.
Please, note hardware EF 000024 position.
Por favor, observe la posición del herraje EF 000024.

PASSO 8 / STEP 8 / PASO 8

Encaixe as peças 12, 13 e 14 entre os espaços específicos.
Fit pieces 12, 13 and 14 in the specific spaces.
Fije las piezas 12, 13 y 14 entre los espacios específicos.

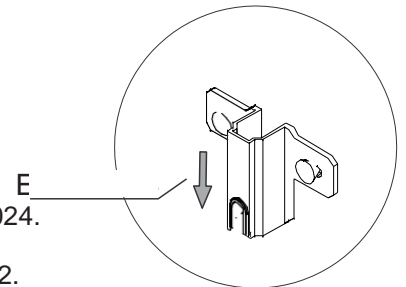
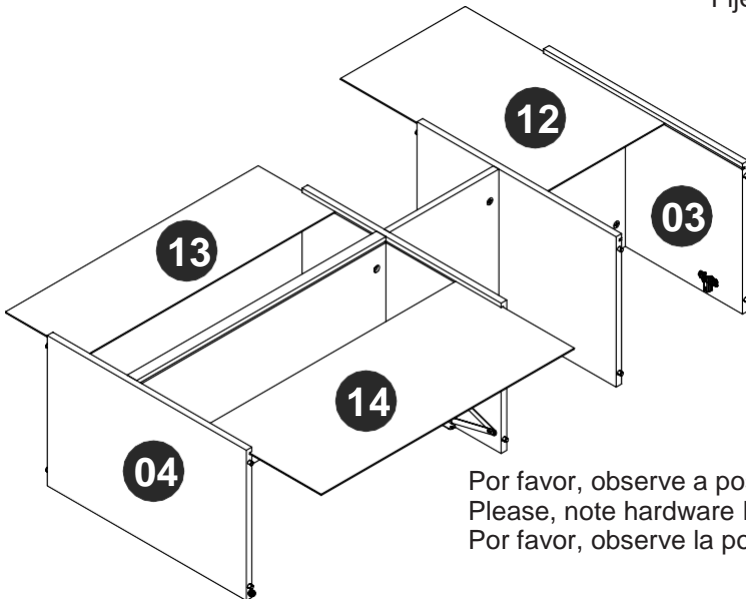

Por favor, observe a posição da ferragem EF 000024.
Please, note hardware EF 000024 position.
Por favor, observe la posición del herraje EF 00002.

PASSO 9 / STEP 9 / PASO 9

Fixe as peças 15 à peça 01 utilizando a ferragem EF 000745 e EF 000741.
Fix pieces 15 to piece 01 using hardware EF 000745 and EF 000741.
Junte las piezas 01 y 15 utilizando los herrajes EF 000745 y EF 000741.

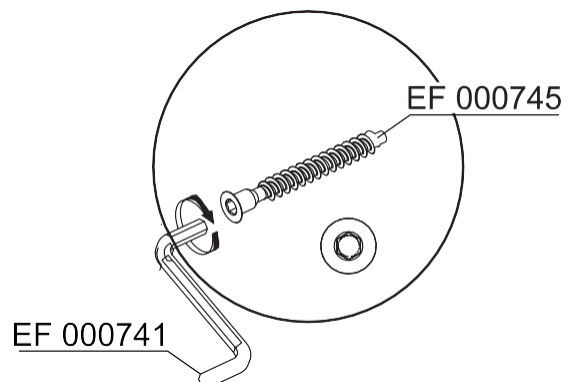
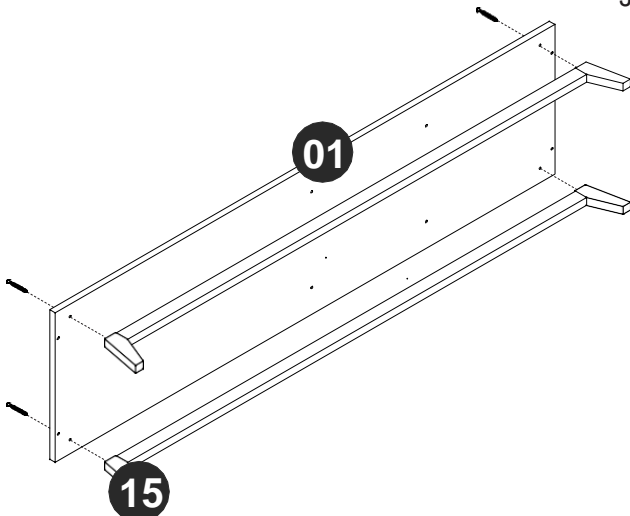

PASSO 10 / STEP 10 / PASO 10

Conecte as partes montadas nos passos 8 e 9 utilizando a ferragem EF 000132.
Connect the parts assembled in the steps 8 and 9 using hardware EF 000132.
Junte las partes armadas en los pasos 8 y 9 utilizando el herraje EF 000132.

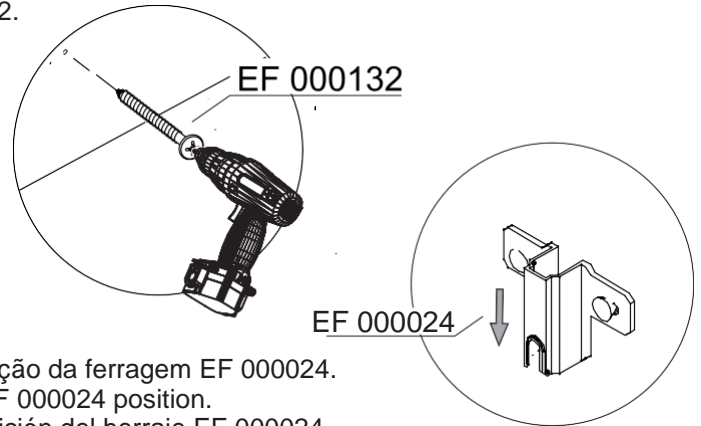
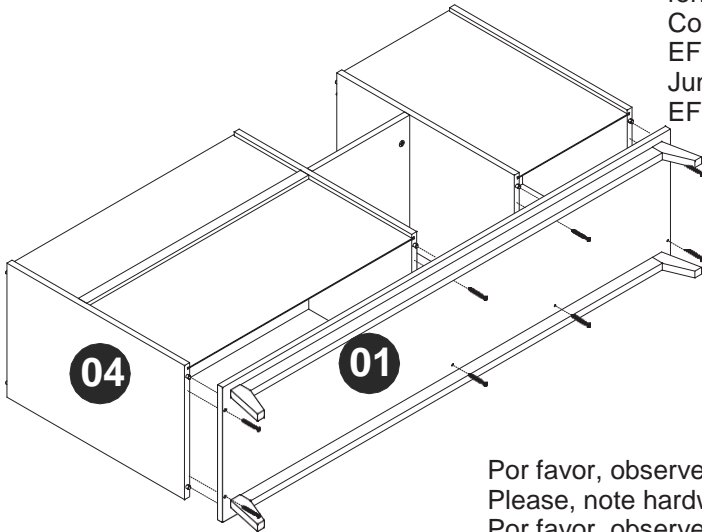

Por favor, observe a posição da ferragem EF 000024.
Please, note hardware EF 000024 position.
Por favor, observe la posición del herraje EF 000024.

PASSO 11 / STEP 11/ PASO 11

Gire o móvel para conectar a peça 02 à parte montada no passo anterior, insira a ferragem EF 000216 e gire para apertar.
Turn the furniture to connect piece 02 to the part assembled in the previous step insert hardware EF 000216 and turn to tighten.
Vire el mueble para juntar la pieza 02 a la parte armada en el paso anterior, añade el herraje EF 000216 y gire para apretar.

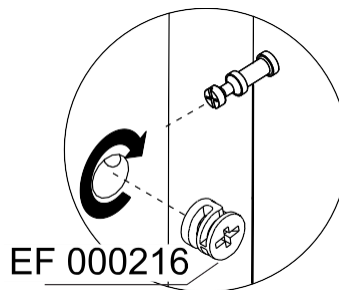
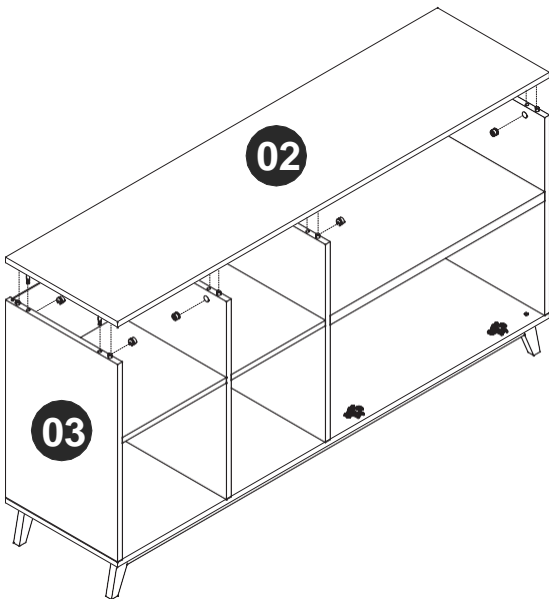

PASSO 12 / STEP 12 / PASO 12

Fixe as peças 10 e 11 ao móvel montado.
Attach pieces 10 and 11 to assembled furniture.
Fije las piezas 07 y 08 al mueble armado.

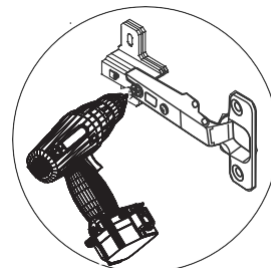
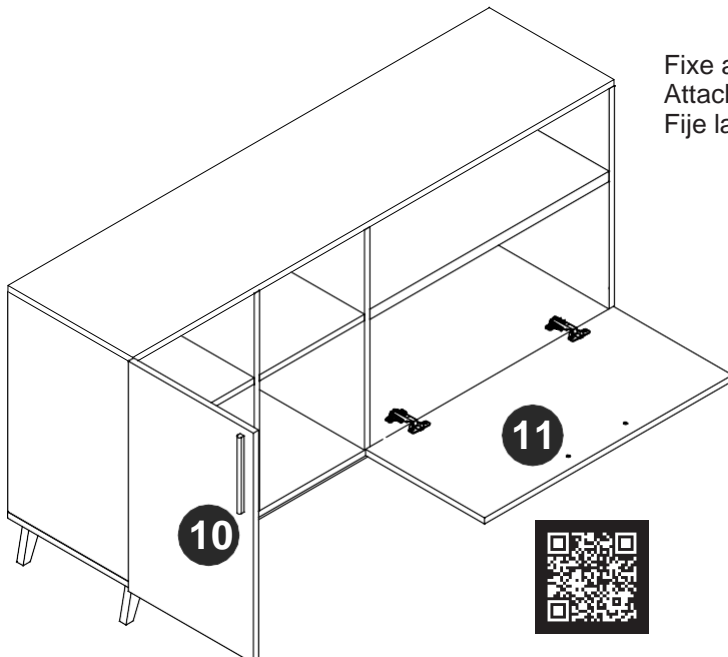

PASSO 13 / STEP 13 / PASO 13

Fixe os articuladores utilizando a ferragem EF 000106.
Attach the articulators using hardware EF 000106.
Fije los articuladores utilizando el herraje EF 000106.

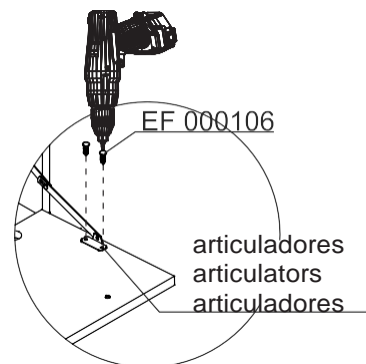
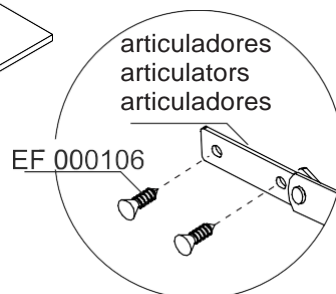
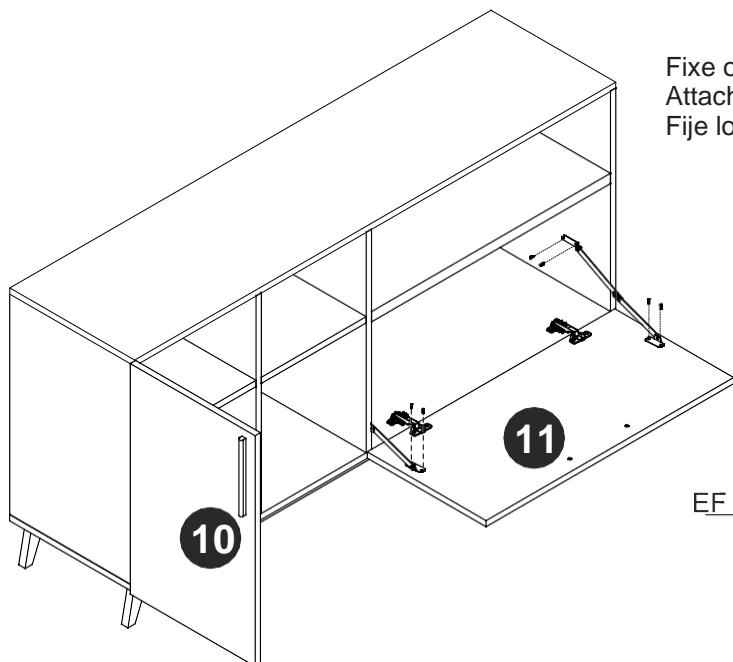

PASSO 14 / STEP 14/ PASO 14

Utilize o tapa furos para cobrir os parafusos aparentes.
Use the sticker to cover the apparent screws.
Utilice los tapa huecos para cubrir los tornillos aparentes.

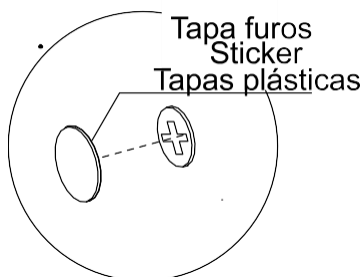
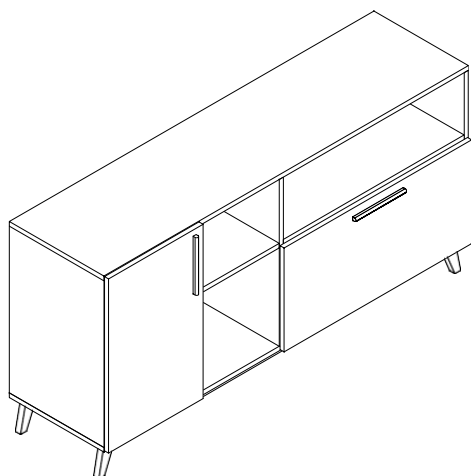

PASSO 15 / STEP 15 / PASO 15

Utilize o giz para dar o acabamento final ao produto.
Use the chalk to give the final finish on the product.
Utilize la tiza para dar el acabado final al producto.

