

## ASSEMBLY INSTRUCTIONS



## Summary

Introduction	-----	3
Avoid accidents	-----	3
Before starting	-----	4
Cleaning	-----	4
Dimensions and tools	-----	5
Identifying parts	-----	6
Hardware included in box	-----	7
Weight Capacity	-----	8
Furniture assembly	-----	8

## Introduction

Read this manual and follow the steps in order to keep the guarantee and also for the perfect fit.

## Avoid accidents

We request you to carefully observe the assembly instructions as: fixing the product on the wall, adding glue in needed and specifics places, product weight limit, etc.



Do not climb or lean on the furniture.

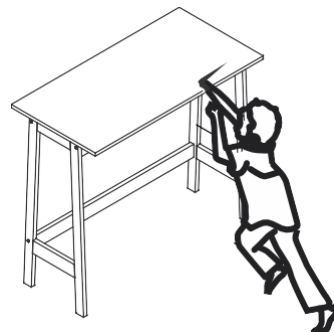

## Before starting

Prepare the room before starting the assembly, leaving it completely clean and the area in good condition to start the work.

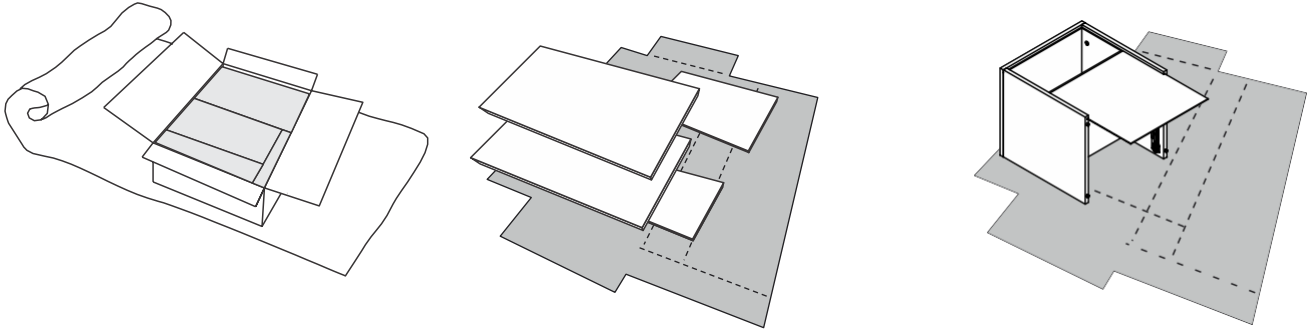

Use the cardboard of the packaging to separate and support the parts removed from the boxes.

Cover the assembly area with a blanket or carpet to avoid damaging the parts during the assembly process.



---

## Cleaning

Slight dampened cloth and after a dry cloth, do not use chemicals or abrasives.

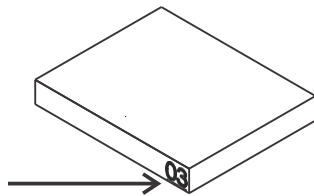

**USE ALCOHOL ONLY TO REMOVE PART NUMBERS AFTER ASSEMBLY**



## Dimensions and tools

Dimensions:

W: 35.43 H: 31.29 D: 17.71 inches

W: 535 H: 735 D: 350 mm

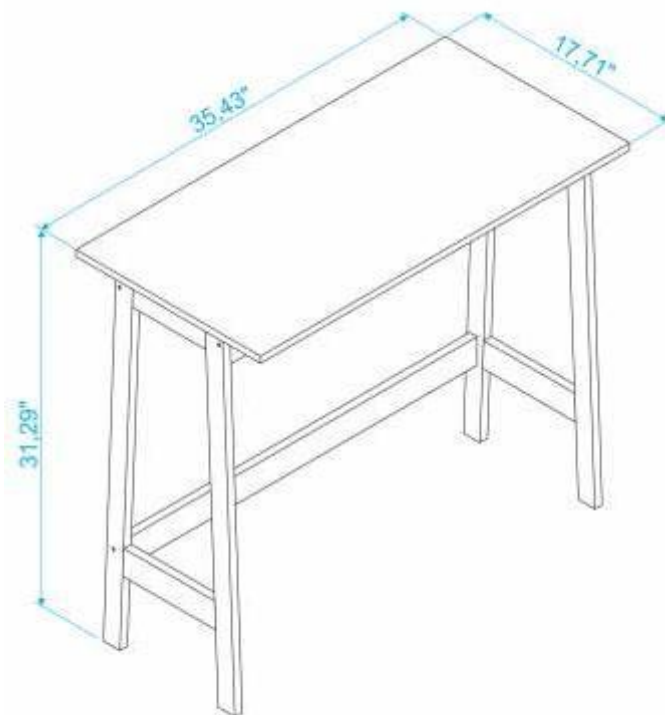

*You may need help to assembly easier.*

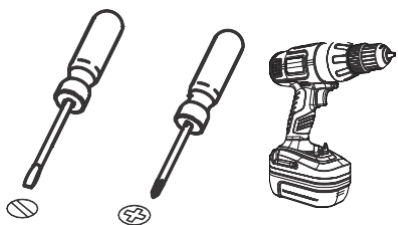

To improve assembly, use an electronic screwdriver.

# Identifying parts

PART	DESCRIPTION	QTY
01	TOP .....	1
02	FEET .....	2
03	TRAVERSE .....	3

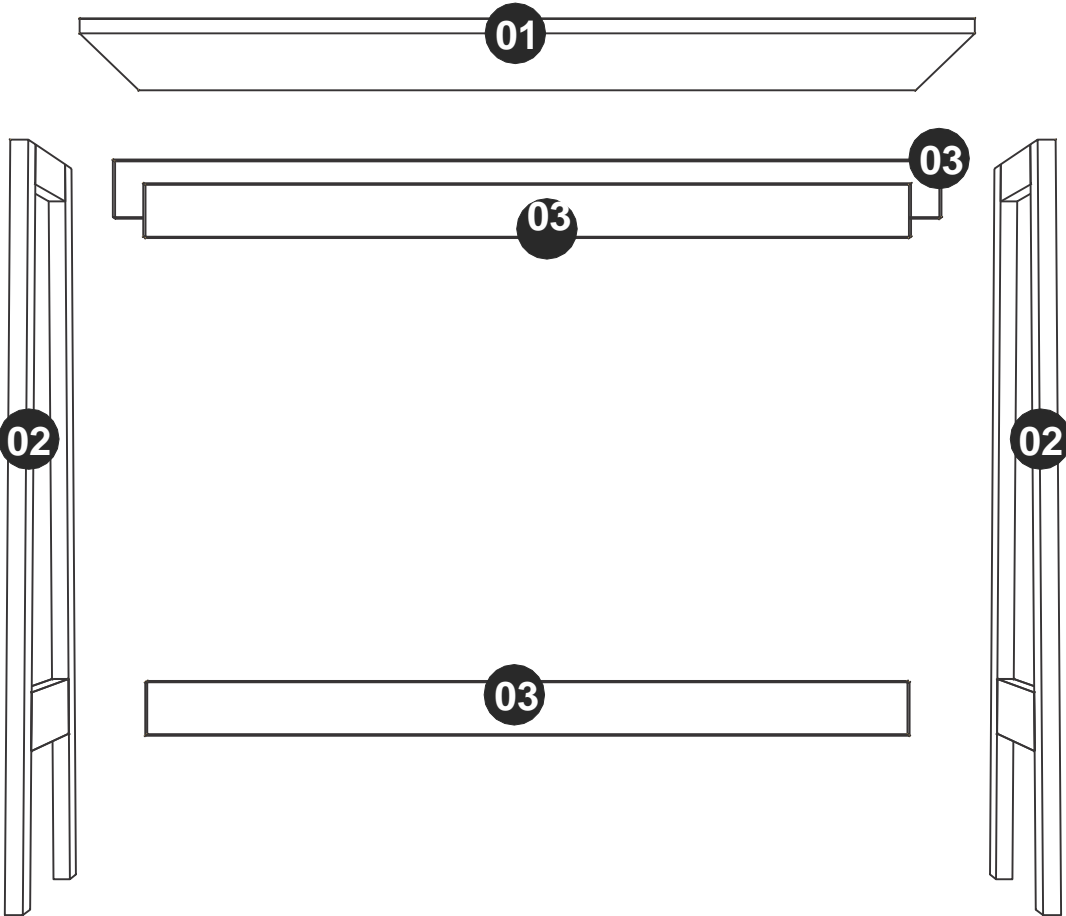

HARDWARE INCLUDED IN BOX 01



EF 000033 x 8

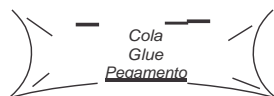

EF 000008 X 1



EF 000113 X 4



EF 000745 - 4



CHALK x 1

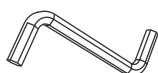

EF 000741 - 1

# Weight Capacity

 = 14KG -30.86LB

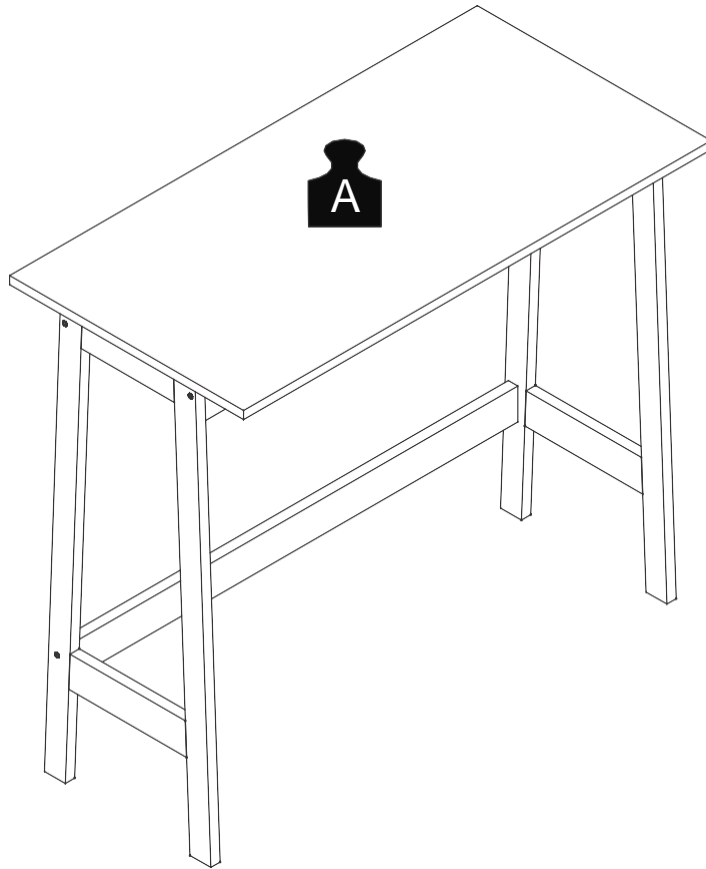

---

## STEP 1

Use the glue before connecting hardware EF 000033 into pieces 01 and 03.

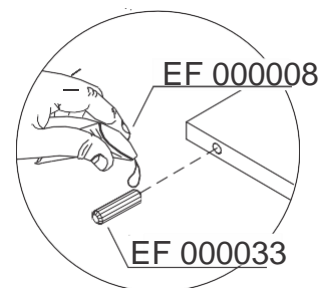
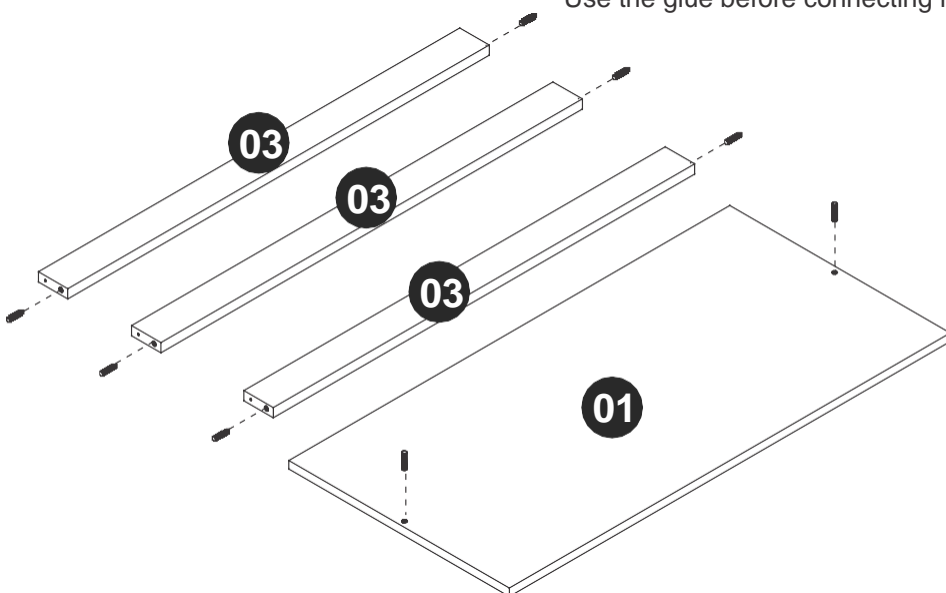



## STEP 2

Connect pieces 02 and 03 using hardware EF 000132.

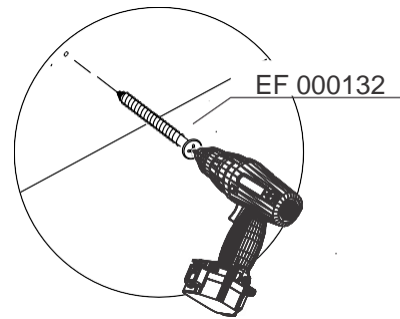
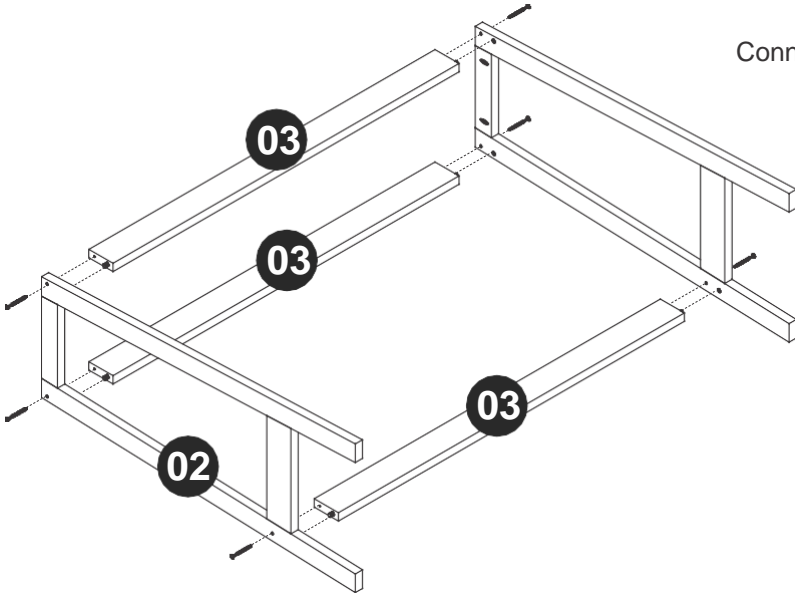

## STEP 3

Connect piece 01 using hardware EF 000113.

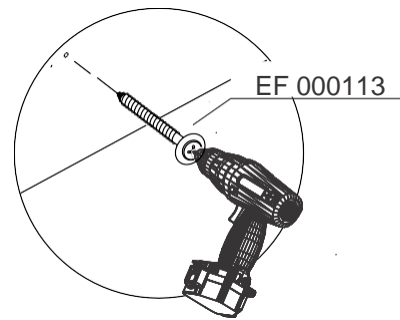
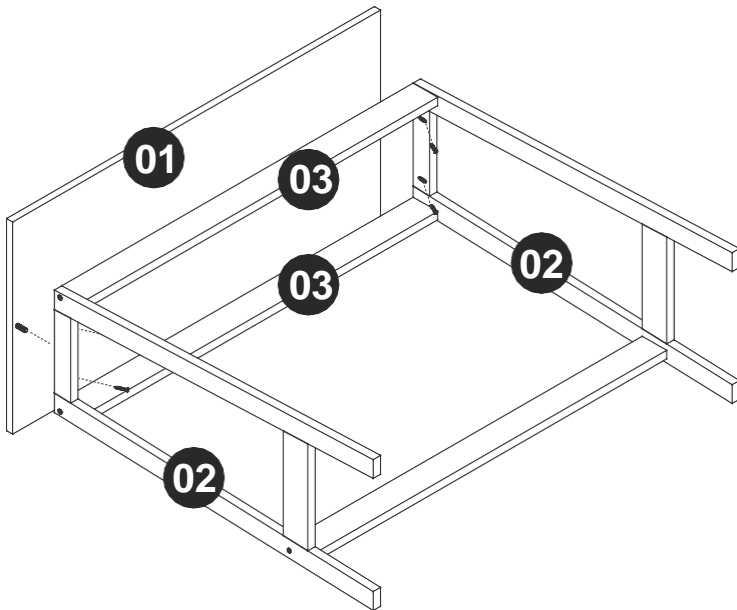

## STEP 4

Use the chalk to give the final finish on the product.

