

ASSEMBLY INSTRUCTIONS AND WARRANTY
MANUAL DE ENSAMBLE Y GARANTIA

**-This instruction manual contains important information. Follow the consecutive order.
Please read and keep for future reference.**

**-Este Manual contiene información importante. Siga el orden consecutivo de las instrucciones.
Por favor léalo y guárdelo para consultas en el futuro.**



Two or more people are required to assemble and/or move this unit.
Se requiere de dos o más personas para armar y mover este mueble.



Unpack and assemble this unit in an spacious area, Assemble the unit on top of the empty box to prevent scratches.
Desempaque y arme este mueble en un area espaciosa. Arme el mueble sobre su caja, para no rayarlo.



Protect furniture from water and moisture. This furniture must not be used outdoors.
Proteja el mueble del agua y de la humedad. No ubique este mueble al aire libre.



Do not expose it to heat.
No lo exponga al calor.



Do not hit or tap with a hammer, unless it is indicated.
No lo golpee ni lo martille.



Do not paint or use abrasive elements to clean this furniture.
No pinte ni use elementos abrasivos para limpiar este mueble.



Do not drag or climb on your furniture. If you need to move it, lift it.
No lo arrastre ni se suba al mueble. Si necesita moverlo, levántelo.

**TOOLS REQUIRED
HERRAMIENTAS REQUERIDAS**



**HAMMER/
MARTILLO**



**PHILLIPS SCREWDRIVER /
ATORNILLADOR DE ESTRELLA**

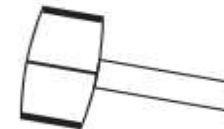

**RUBBER
HAMMER/
MARTILLO
DE GOMA**

PARTS IDENTIFICATION / IDENTIFICACIÓN DE PIEZAS

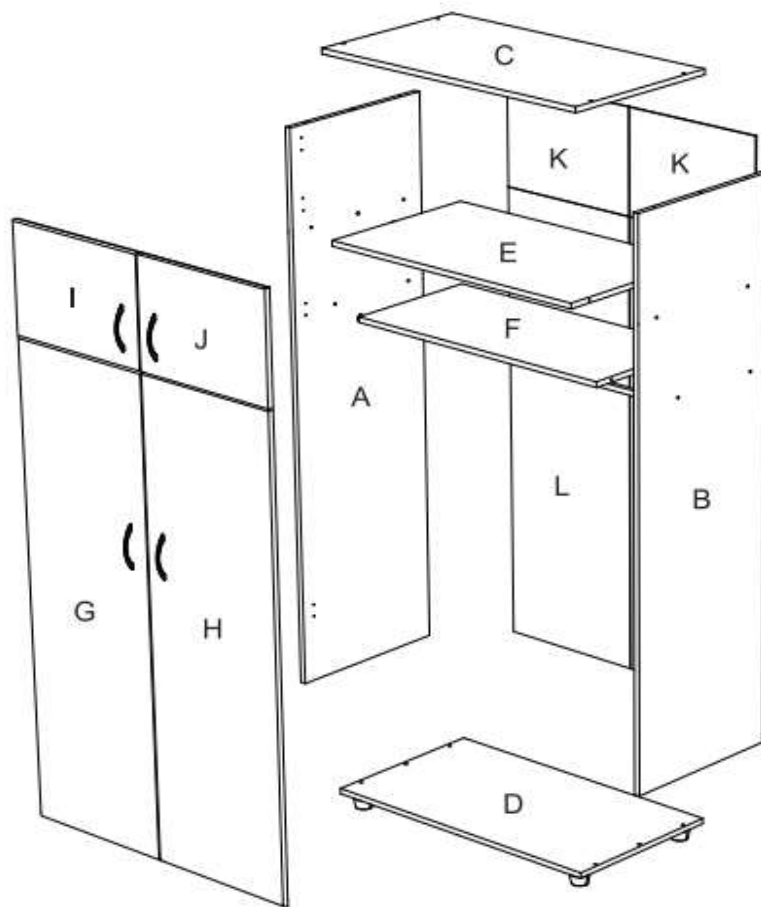

PARTS PIEZA	QUANTITY CANTIDAD
A	1
B	1
C	1
D	1
E	1
F	1
G	1
H	1
I	1
J	1
K	2
L	2

QUANTITY CANTIDAD	FROM DESDE	TO HASTA
14	A	L

HARDWARE IDENTIFICATION / IDENTIFICACIÓN DE HERRAJES

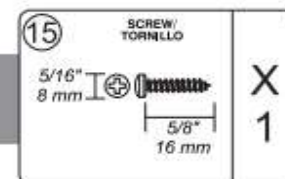
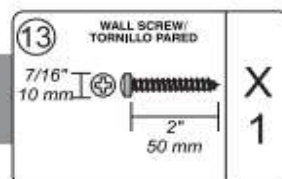
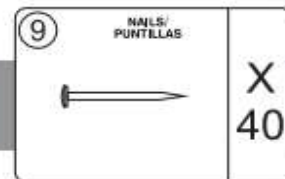
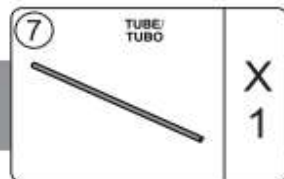
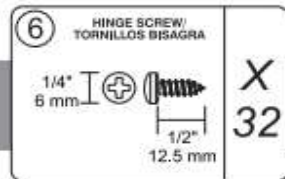
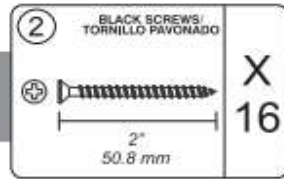
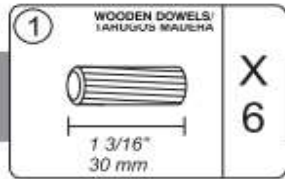

PARTS PREPARATION / PREPARACIÓN DE PARTES

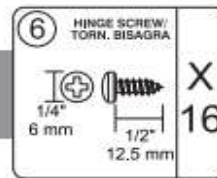
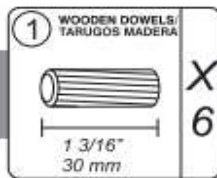
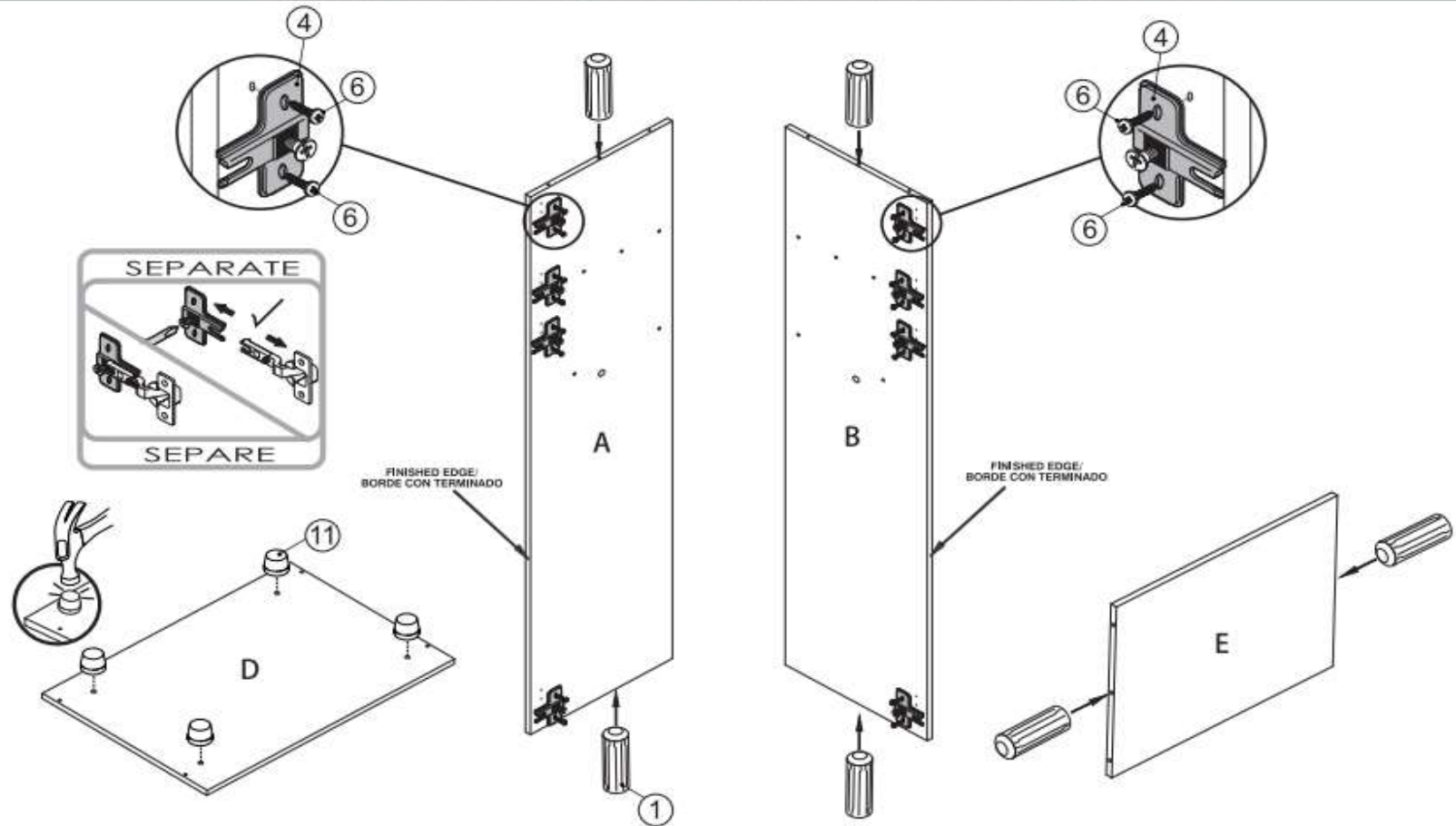

FURNITURE ASSEMBLY / ARMADO DEL MUEBLE

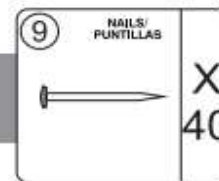
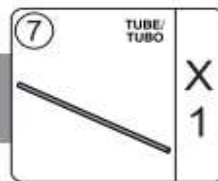
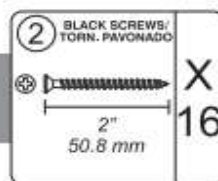
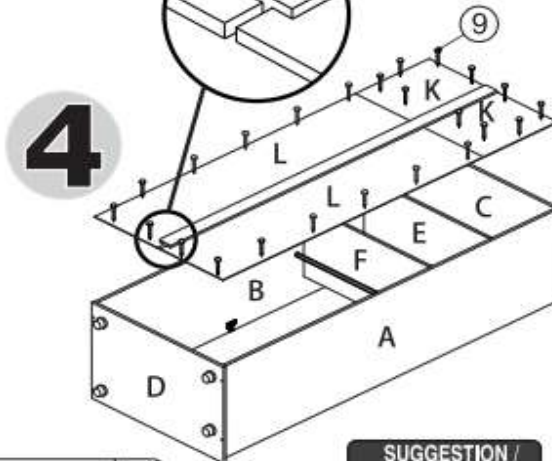
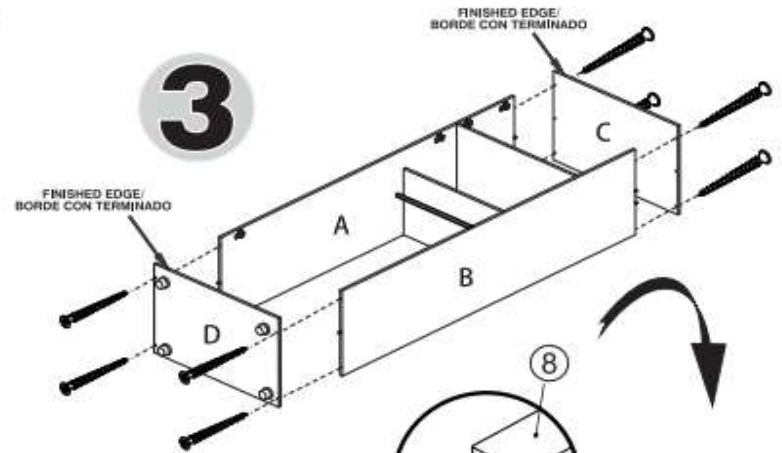
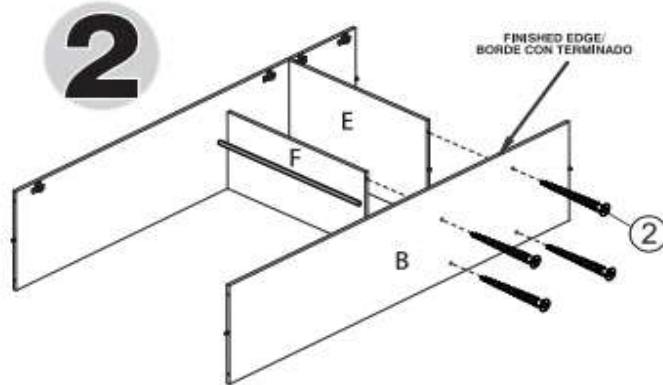
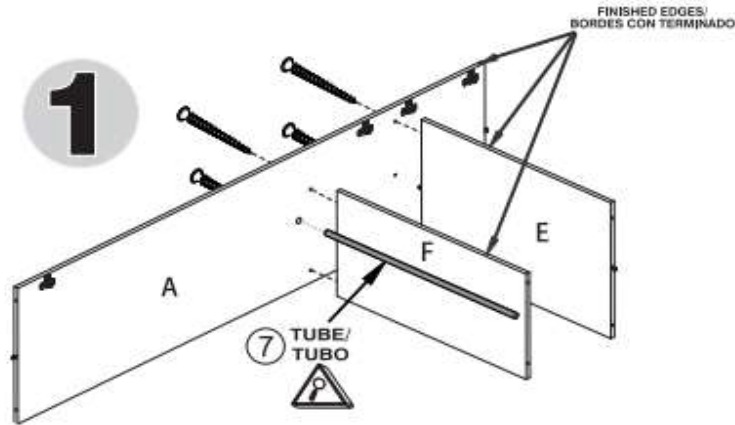

SUGGESTION /
ASSEMBLE ON A FLAT
AND CLEAN SURFACE
TO AVOID DAMAGES./
ARME SOBRE UNA
SUPERFICIE LIMPIA Y
PLANA
PARA EVITAR POSIBLES
AVERIAS.
SUGERENCIA

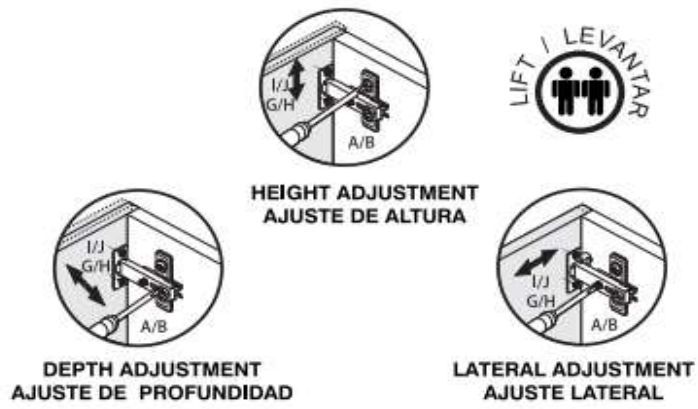

6

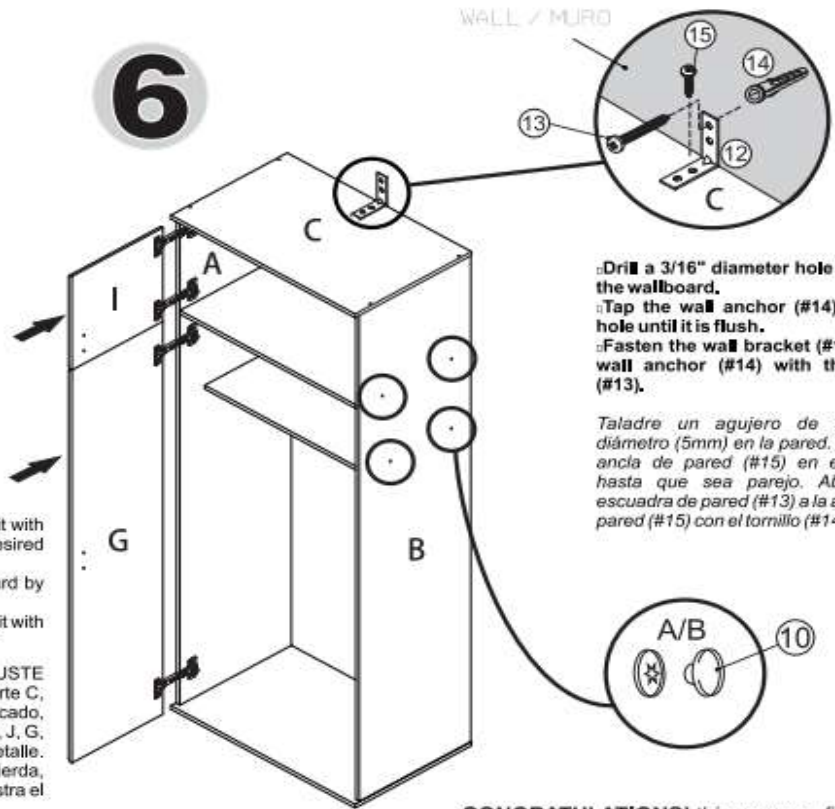

Drill a 3/16" diameter hole (5mm) in the wallboard.
 Tap the wall anchor (#14) into the hole until it is flush.
 Fasten the wall bracket (#12) to the wall anchor (#14) with the screw (#13).

Taladre un agujero de 3/16" de diámetro (5mm) en la pared. Golpee la ancla de pared (#14) en el agujero hasta que sea parejo. Abroche la escuadra de pared (#12) a la ancla de la pared (#14) con el tornillo (#13).

To level the Door Parts "I", "J", "G", "H", follow these steps:
HEIGHT ADJUSTMENT: Allows Parts "I", "J", "G", "H", to be raised or lowered to level it with parts "C". Loosen the Hinge screw, as shown in the detail, to adjust the door to the desired position, and retighten the Hinge screws.
DEPTH ADJUSTMENT: Allows Parts "I", "J", "G", "H" to be moved forward or backward by loosening the Hinge screw as shown in the detail.
LATERAL ADJUSTMENT: Allows Parts "I", "J", "G", "H" to be moved right or left, leveling it with parts "A", "B" by loosening or tightening the Hinge screw as shown in the detail.

Para nivelar las puertas partes I, J, G, H, tenga en cuenta las siguientes indicaciones: **AJUSTE DE ALTURA:** Le permite subir o bajar las partes I, J, G, H, cuadrándola al nivel de la parte C, aflojando el tornillo de la bisagra, como lo muestra el detalle. Cuando este en el lugar indicado, asegure los tornillos bisagra. **AJUSTE DE PROFUNDIDAD:** Le permite llevar las partes I, J, G, H, hacia adentro o hacia afuera, aflojando el tornillo de la bisagra, como lo muestra el detalle. **AJUSTE LATERAL:** Le permite llevar las partes I, J, G, H, hacia la derecha o la izquierda, nivelándola con la parte A, B aflojando o apretando el tornillo de la bisagra, como lo muestra el detalle.

CONGRATULATIONS! this way you finished assembling your furniture.

FELICITACIONES! de esta manera usted termina de armar su mueble.

<p>10 SCREW CAPS/ TAPA TORNILLO</p>	X 8	<p>12 WALL BRACKET/ ESCUADRA DE PARED</p>	X 1	<p>13 WALL SCREW/ TORNILLO PARED</p> <p>7/16" 10 mm</p> <p>2" 50 mm</p>	X 1	<p>14 WALL ANCHOR/ CHAZO ANCLAJE PARED</p>	X 1	<p>15 SCREW/ TORNILLO</p> <p>5/16" 8 mm</p> <p>5/8" 16 mm</p>	X 1
---	--------	---	--------	---	--------	--	--------	---	--------